

Plug-in module SIRAX TV 808, 2 channels

Isolating amplifier unipolar/bipolar

For electrically insulating, amplifying and converting DC signals



Application

The purpose of the isolating amplifier **SIRAX TV 808** (Fig. 1) is to electrically insulate input and output signals, respectively to amplify and/or change the signal level or type (current or voltage) of the input signals.

The instrument fulfils all the important requirements and regulations concerning electromagnetic compatibility **EMC** and **Safety** (IEC 1010 resp. EN 61 010). It was developed and is manufactured and tested in strict accordance with the **quality assurance standard ISO 9001**.

The device has two channels and provides two independent isolating amplifiers in an extremely small space. The user has a wide choice of input and output ranges and can set the desired one with the aid of soldered jumpers and potentiometers.

A version with one input and two outputs is available that enables two electrically insulated outputs to be obtained from a single input signal.

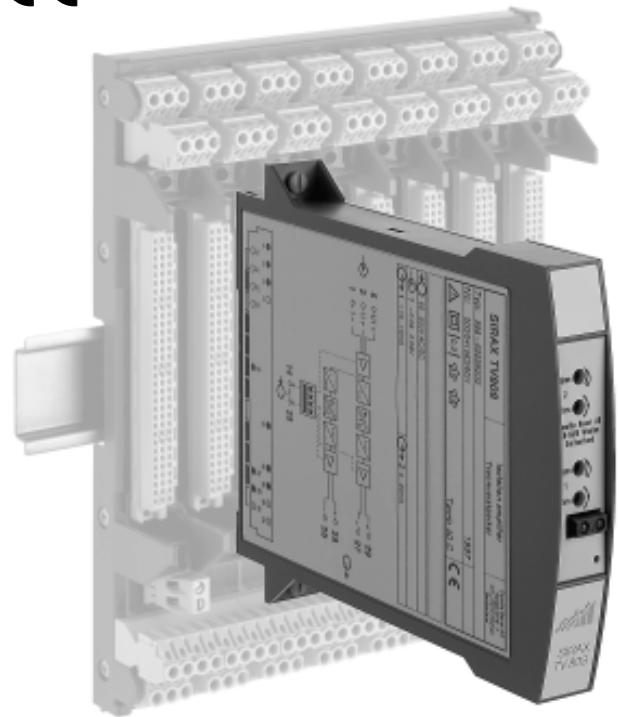

Fig. 1. Plug-in module SIRAX TV 808-62 for plugging onto backplane BP 902.

Variants

- 252 standard input and output combinations selected by soldered jumpers
- User-specific input and/or output ranges
- Isolating amplifier with one input and two electrically insulated outputs
- Power supply 24...60 V DC/AC or 85...230 V DC/AC

Please request our data sheet TV 808-61 Le for single-channel versions.

Features / Benefits

- Isolating amplifier plugs onto backplane (mechanically latched by fasteners), all electrical connections made to the backplane and not to the SIRAX TV 808 / Thus no wiring when replacing devices
- Electric insulation between inputs, outputs (2.3 kV) and power supply 3.7 kV / Prevents measurement errors due to potential leakage
- Flexibility provided by more than 250 different input and output combinations selected by simply positioning soldered jumpers / Reduced stocking
- Non-standard user-specific ranges available
- AC/DC power supply / Universal

Standard versions

Inputs and outputs set to 0...20 mA. Any of the standard ranges given in the Section "Technical data, measuring inputs" are simply selected by positioning soldered jumpers. The fine adjustment is accomplished using the potentiometers "Zero" and "Span".

Table 1: Standard version with 2 inputs and 2 outputs

Standard range		Power supply	Order No.
Inputs 1 and 2	Outputs 1 and 2		
0... 20 mA	0... 20 mA	24... 60 V DC/AC	128 927
		85...230 V DC/AC	128 935

Table 2: Standard version with 1 input and 2 outputs

Standard range		Power supply	Order No.
Input 1	Outputs 1 and 2		
0... 20 mA	0... 20 mA	24... 60 V DC/AC	128 943
		85...230 V DC/AC	128 951

Please complete the Order Code 808-62.. according to «Table 4: Ordering informations» for versions with user-specific input and/or output ranges.

Plug-in module SIRAX TV 808, 2 channels

Isolating amplifier unipolar/bipolar

Technical data

Measuring inputs \rightarrow

DC current:

Standard ranges

0 ... 0.1 mA	0.2 ... 1 mA	- 0.1 ... + 0.1 mA
0 ... 0.2 mA	1 ... 5 mA	- 0.2 ... + 0.2 mA
0 ... 0.5 mA	2 ... 10 mA	- 0.5 ... + 0.5 mA
0 ... 1 mA	4 ... 20 mA	- 1 ... + 1 mA
0 ... 2 mA		- 2 ... + 2 mA
0 ... 5 mA		- 5 ... + 5 mA
0 ... 10 mA		- 10 ... + 10 mA
0 ... 20 mA		- 20 ... + 20 mA

Limit values

0...0.1 to 0...40 mA

also live-zero,

start value > 0 to \leq 50% final value

or span 0.1 to 40 mA

between -40 and 40 mA

also bipolar asymmetrical

$$R_i = 15 \Omega$$

DC voltage:

Standard ranges

0 ... 0.06 V	0.2 ... 1 V	- 0.1 ... + 0.1 V
0 ... 0.1 V	1 ... 5 V	- 0.2 ... + 0.2 V
0 ... 0.2 V	2 ... 10 V	- 0.5 ... + 0.5 V
0 ... 0.5 V	4 ... 20 V	- 1 ... + 1 V
0 ... 1 V		- ... + 2 V
0 ... 2 V		- 5 ... + 5 V
0 ... 5 V		- 10 ... + 10 V
0 ... 10 V		- 20 ... + 20 V
0 ... 20 V		
0 ... 40 V		

Limit values

0...0.06 to 0...40

also live-zero,

start value > 0 to \leq 50% final value

or span 0.06 to 40 V

between -40 and 40 V

also bipolar asymmetrical

$$R_i = 100 \text{ k}\Omega$$

Overload:

DC current
continuously 2-fold

DC voltage
continuously 2-fold

Measuring outputs \rightarrow

DC current:

Standard ranges
0...20 mA, 4...20 mA, \pm 20 mA

Limit values

0...1 to 0...20 mA
0.2...1 to 4...20 mA
- 1...0...+ 1 to - 20...0...+ 20 mA

Burden voltage:

12 V

External resistance:

$$R_{\text{ext max.}} [\text{k}\Omega] = \frac{12 \text{ V}}{I_{\text{AN}} [\text{mA}]}$$

I_{AN} = Output circuit full-scale value

DC voltage:

Standard ranges
0...10 V, 2...10 V, \pm 10 V

Limit values

0...1 to 0...10 V
0.2...1 to 2...10 V
- 1...0...+ 1 to - 10...0...+ 10 V

Burden:

$$R_{\text{ext min.}} [\text{k}\Omega] \geq \frac{U_{\text{AN}} [\text{V}]}{5 \text{ mA}}$$

U_{AN} = Output circuit full-scale value

Current limiter at

$R_{\text{ext max.}}$:

Approx. $1.1 \times I_{\text{AN}}$ for current output

Voltage limiter at

$R_{\text{ext}} = \infty$:

Approx. 13 V

Residual ripple in

output current:

0.5% p.p.

Response time:

< 50 ms

Power supply H \rightarrow

AC/DC power pack (DC and 45...400 Hz)

Table 3: Nominal voltages and tolerances

Nominal voltage U_N	Tolerance
24 ... 60 V DC / AC	DC - 15 ... + 33%
85 ... 230 V ¹ DC / AC	AC \pm 15%

Power input:

\leq 1.6 W resp. \leq 3.4 VA

Accuracy data (acc. to DIN/IEC 770)

Basic accuracy:

Limit error $\leq \pm$ 0.2%
Including linearity and reproducibility errors

Reference conditions:

Ambient temperature

23 °C, \pm 2 K

Power supply

24 V DC \pm 10% and 230 V AC \pm 10%

Output burden

Current: $0.5 \cdot R_{\text{ext max.}}$
Voltage: $2 \cdot R_{\text{ext min.}}$

Influencing factors:

Temperature

< \pm 0.1% per 10 K

Burden influence

< \pm 0.1% for current output
< \pm 0.2% for voltage output
if $R_{\text{ext}} < 2 \cdot R_{\text{ext min.}}$

¹ For power supplies > 125 V, the auxiliary circuit should include an external fuse with a rating \leq 20 A DC.

Longtime drift	< ± 0.3% / 12 months
Switch-on drift	< ± 0.2%
Common and transverse mode influence	< ± 0.2%
Output + or – connected to ground	< ± 0.2%

Installation data

Housing:	Isolating amplifier in housing B17 for plugging onto backplane BP 902. Refer to Section “Dimensional drawing” for dimensions
Material of housing:	Lexan 940 (polycarbonate) flammability class V-0 acc. to UL 94, self-extinguishing, non-dripping, free of halogen
Designation:	SIRAX TV 808
Mounting position:	Any
Electrical connections:	96-pin connector acc. to DIN 41 612, pattern C Layout see Section “Electrical connections”
Coding:	Isolating amplifier supplied already coded. The rack is coded by the user by fitting the coding inserts supplied
Weight:	Approx. 0.18 kg

Electrical insulation: All circuits (measuring input / measuring output / power supply) are electrically insulated

Regulations

Electromagnetic compatibility:	The standards DIN EN 50 081-2 and DIN EN 50 082-2 are observed
Protection (acc. to IEC 529 resp. EN 60 529):	Housing IP 40 Terminals IP 00
Electrical standards:	Acc. to IEC 1010 resp. EN 61 010
Operating voltages:	< 300 V between all insulated circuits
Contamination level:	2
Overvoltage category acc. to IEC 664:	III for power supply II for measuring input and measuring output
Double insulation:	– Power supply versus all other circuits – Measuring input versus measuring output

Test voltage:	Power supply versus: – all 3.7 kV, 50 Hz, 1 min. Measuring inputs versus: – measuring outputs 2,3 kV, 50 Hz, 1 min. Measuring input 1 versus: – measuring input 2 2.3 kV, 50 Hz, 1 min. Measuring output 1 versus: – measuring output 2 2.3 kV, 50 Hz, 1 min.
---------------	--

Environmental conditions

Climatic rating:	Climate class 3Z acc. to VDI/VDE 3540
Commissioning temperature:	– 10 to + 55 °C
Operating temperature:	– 25 to + 55 °C
Storage temperature:	– 40 to + 70 °C
Annual mean relative humidity:	≤ 75%

Plug-in module SIRAX TV 808, 2 channels

Isolating amplifier unipolar/bipolar

Table 4: Ordering informations (see also Table 1 and 2: "Standard versions")

DESCRIPTION	MARKING
1. Mechanical design Housing B17 (for plugging onto backplane BP 902, see data sheets BP 902)	808 - 6
2. Number of channels 2) 2 channels	2
3. Version / Power supply 1) Standard, 24 ... 60 V DC/AC 2) Standard, 85 ... 230 V DC/AC	1 2
4. Function 2) 2 inputs, 2 electrically insulated outputs 3) 1 input, 2 electrically insulated outputs	2 3
5. Input signal, input 1 9) Input [V] <input type="text"/> Z) Input [mA] <input type="text"/> Line 9: [M] 0 ... 0.06 to 0 ... 40 also live-zero, start value > 0 to ≤ 50% final value or span 0.06 to 40 V between -40 and 40 V also bipolar asymmetrical Line Z: [mA] 0 ... 0.1 to 0 ... 40 also live-zero, start value > 0 to ≤ 50% final value or span 0.1 to 40 mA between -40 and 40 mA also bipolar asymmetrical	9 Z
6. Output signal, output 1 9) Output [V] <input type="text"/> Z) Output [mA] <input type="text"/> Line 9: [M] 0 ... 1 to 0 ... 10 0.2 ... 1 to 2 ... 10 -1 ... 0 ... +1 to -10 ... 0 ... +10 Line Z: [mA] 0 ... 1 to 0 ... 20 0.2 ... 1 to 4 ... 20 -1 ... 0 ... +1 to -20 ... 0 ... +20	9 Z
7. Input signal, input 2 0) Without input 2 9) Input [V] <input type="text"/> Z) Input [mA] <input type="text"/> Ranges possibles see input 1	0 9 Z
8. Output signal, output 2 9) Output [V] <input type="text"/> Z) Output [mA] <input type="text"/> Ranges possibles see output 1	9 Z

Possible special versions, e.g. increased climatic rating on inquiry.

Electrical connections

SIRAX TV 808
Front

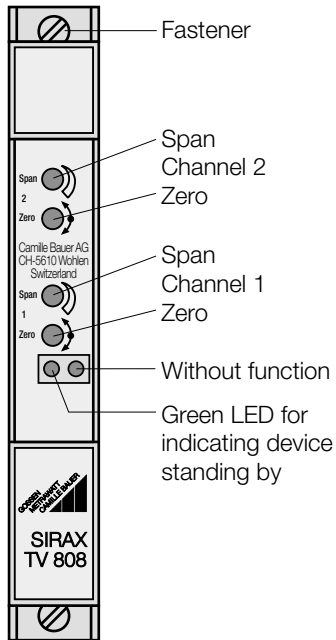

SIRAX TV 808
Rear

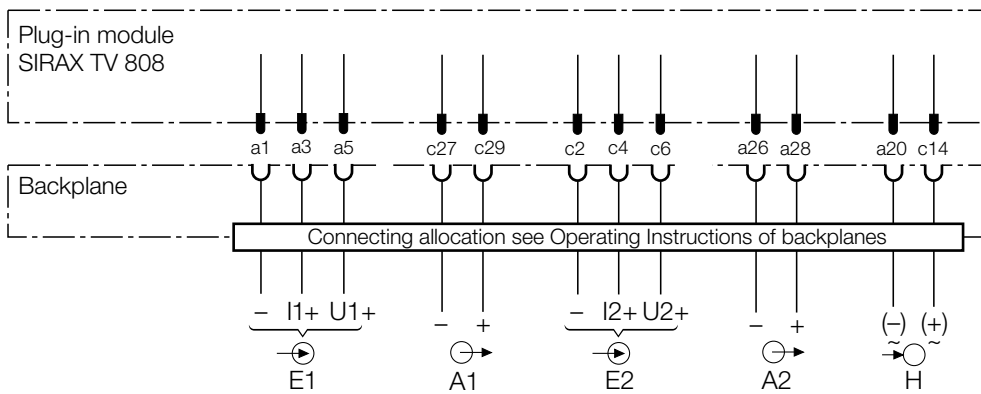
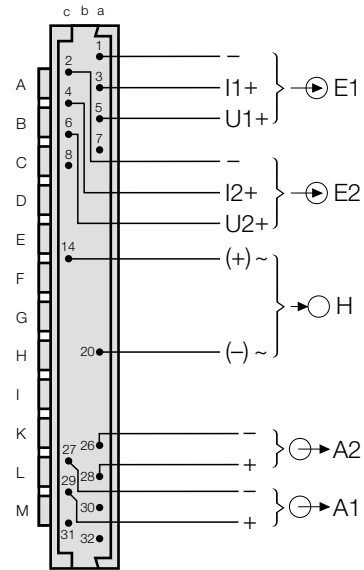

E1 = Input 1
E2 = Input 2
A1 = Output 1
A2 = Output 2
H = Power supply

Plug-in module SIRAX TV 808, 2 channels

Isolating amplifier unipolar/bipolar

Configuration

1. Standard input ranges

Soldered jumpers are provided for the coarse setting of the input ranges and the fine adjustment is accomplished using the potentiometers "Zero" and "Span".

100 must be added to the designations of the soldered jumpers in the table for channel 1 and 200 for channel 2.

(Example: Input range for input 1 and input 2 = 0...20 mA. Jumpers 1, 5, 6 and 11 must be inserted for this range.

- The corresponding jumpers for channel 1 are B 101, B 105, B 106 and B 111.
- The corresponding jumpers for channel 2 are B 201, B 205, B 206 and B 211).

Current [mA]	Soldered jumpers			Voltage [V]	Soldered jumpers		
	1	2	3		4	5	6
0 ... 0.1	1, 3	7, 10, 11		0 ... 0.06		7, 9, 10, 11	
0 ... 0.2	1, 3	8, 11		0 ... 0.1		7, 8, 10, 11	
0 ... 0.5	1, 4	9, 10, 11		0 ... 0.2		6, 8, 9, 11	
0 ... 1	1, 4	7, 10, 11		0 ... 0.5		7, 10	
0 ... 2	1, 4	8, 11		0 ... 1	2	6, 7, 8, 10, 11	
0 ... 5	1, 5	6, 7, 8, 10, 11		0 ... 2	2	7, 8, 9, 11	
0 ... 10	1, 5	10, 11		0 ... 5	2	8, 10	
0 ... 20	1, 5	6, 11		0 ... 10	1	10, 11	
				0 ... 20	1	6, 11	
				0 ... 40	1	8	
0.2 ... 1	1, 4	8, 10, 11	12, 15	0.2 ... 1	2	6, 9, 10, 11	12, 15
1 ... 5	1, 4	6, 9	12, 15	1 ... 5	2	6, 8, 9, 10	12, 15
2 ... 10	1, 5	6, 7, 10, 11	12, 15	2 ... 10	1	6, 7, 10, 11	12, 15
4 ... 20	1, 5	6, 7, 8, 11	12, 15	4 ... 20	1	6, 7, 8, 11	12, 15
- 0.1 ... 0 ... + 0.1	1, 3	8, 11	13, 14, 16	- 0.1 ... 0 ... + 0.1		6, 8, 9, 11	13, 14, 16
- 0.2 ... 0 ... + 0.2	1, 3	7, 9	13, 14, 16	- 0.2 ... 0 ... + 0.2		6, 7, 9, 10	13, 14, 16
- 0.5 ... 0 ... + 0.5	1, 4	7, 10, 11	13, 14, 16	- 0.5 ... 0 ... + 0.5	2	7, 8, 10, 11	13, 14, 16
- 1 ... 0 ... + 1	1, 4	8, 11	13, 14, 16	- 1 ... 0 ... + 1	2	7, 8, 9, 11	13, 14, 16
- 2 ... 0 ... + 2	1, 4	6, 9	13, 14, 16	- 2 ... 0 ... + 2	2	6, 8, 9, 10	13, 14, 16
- 5 ... 0 ... + 5	1, 5	10, 11	13, 14, 16	- 5 ... 0 ... + 5	1	10, 11	13, 14, 16
- 10 ... 0 ... + 10	1, 5	6, 11	13, 14, 16	- 10 ... 0 ... + 10	1	6, 11	13, 14, 16
- 20 ... 0 ... + 20	1, 5	6, 7	13, 14, 16	- 20 ... 0 ... + 20	1	8	13, 14, 16

2. Standard output ranges

Soldered jumpers are provided for the coarse setting of the output ranges and the fine adjustment is accomplished using the potentiometers "Zero" and "Span".

Current [mA]	Soldered jumpers		Voltage [V]	Soldered jumpers	
	Channel 1	Channel 2		Channel 1	Channel 2
0 ... 20	B 120	B 220	0 ... 10	B 120 B 122 B 123	B 220 B 222 B 223
4 ... 20	B 121	B 221	2 ... 10	B 121 B 122 B 123	B 221 B 222 B 223
± 20	—	—	± 10	B 122 B 123	B 222 B 223

3. Specific user output ranges

Units that have been configured for a specific user output range cannot be subsequently reconfigured.

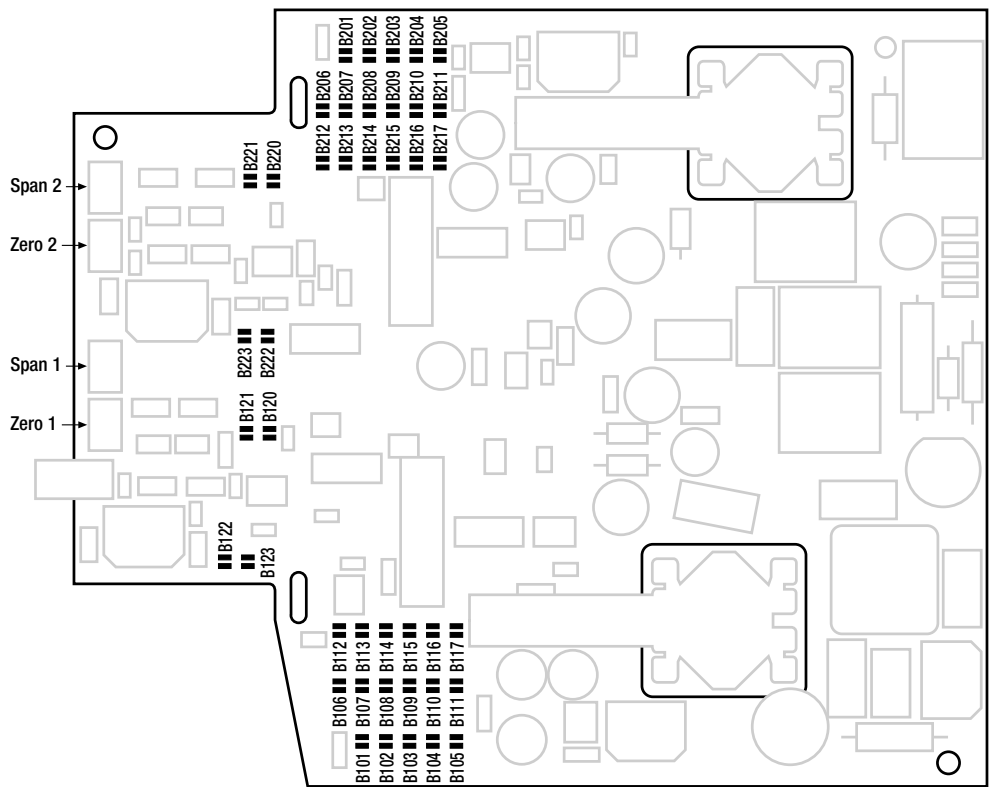

Fig. 2. Position of the soldered jumpers B ... and the potentiometers «Zero» and «Span».

Table 5: Accessories and spare parts

Description	Order No.
Coding comb with 12 sets of codes (for coding the backplane BP 902)	107 971
Operating Instructions TV 808-62 B d-f-e	129 967
Data card (for recording configured settings)	130 956

Standard accessories

- 1 Operating Instructions for SIRAX TV 808 in three languages: German, French, English
- 1 Coding comb with 12 sets of codes
- 3 Data cards (for recording configured settings)

Dimensional drawing

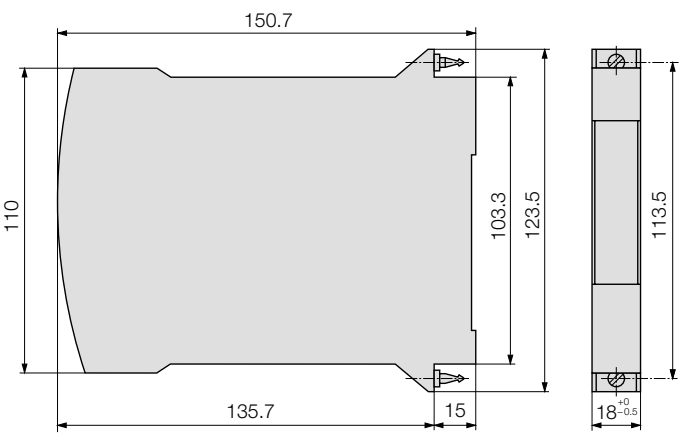

Fig. 3. SIRAX TV 808 in housing B17.

Plug-in module SIRAX TV 808, 2 channels

Isolating amplifier unipolar/bipolar

Printed in Germany • Subject to change without notice • Edition 04.99 • Data sheet No. TV 808-62 Le

Camille Bauer Ltd

Aargauerstrasse 7
CH-5610 Wohlen/Switzerland
Phone +41 56 618 21 11
Fax +41 56 618 24 58
Telex 827 901 cbm ch

GOSSEN
METRAWATT
CAMILLE BAUER

